



## Return Path Receiver

### HRR 4104

#### Product Description

Harmonic's HRR 4104 is a quad return path receiver for the HLP 4200 series and above broadband chassis. The HRR 4104 uses state-of-the-art technologies to provide many distinct features including high packing densities, flexible configurations, and high RF output level. A single HLP 4200 chassis can hold forty return path receivers (ten HRR 4104 units) in three rack units. Harmonic's HRR 4104 return path receiver allows operators to build compact, complete, two-way, interactive broadband communications networks.

In a redundant pair configuration, one receiver in an HRR 4104 is used for primary fiber paths and a second receiver for the backup fiber paths. The RF outputs of the two units are combined. The primary unit mutes the RF output of the backup unit unless the primary unit is in alarm. If the primary unit is in alarm, the backup unit is activated and the primary unit is muted.

The HRR 4104 has the added benefit of offering hot swapping, which allows the card to be added or removed without disrupting service and improves overall network reliability. Each HRR 4104 has four completely independent optical receivers.

#### Advantages

The use of the HRR 4104 in a network offers the operator several advantages for expanding network services and increasing system reliability:

- Ultra high package density (ten HRR 4104 in a three rack unit with 40 return path receivers) provides better use of limited headend space, and lowers powering costs.
- Customizable protection options and easy upgrade to protection switching allow operators to easily adapt protection requirements without disrupting service.

HRR 4104 Block Diagram

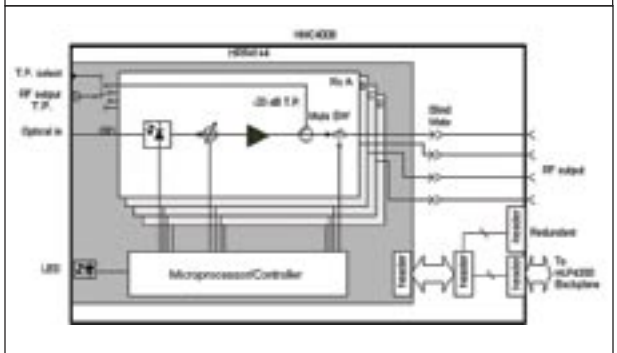

- Operators can offer a complete, two-way interactive system for delivery of pay-per-view, video-on-demand, telephony, and other personal communication services.
- Different levels of monitoring enable operators to upgrade the system as desired.

#### Applications

- Internet access
- Telephony
- Video-on-demand
- Network management
- Pay-per-view
- Data services
- Local origination
- I-net

### Models Available

Standard HRR 4104-AS	SC/APC connector
-------------------------	------------------

Also Available HRR 4104-US	SC/UPC connector
HRR 4104-UF	FC/UPC connector
HRR 4104-AF	FC/APC connector
HRR 4104-AE	E-2000 connector

### Optical Input

Maximum Input	+2 dBm
Minimum Input	-18 dBm
Wavelength	1280 to 1600 nm

### RF Output

C/IM2 <sup>1</sup>	≥ 60 dB
C/IM3 <sup>1</sup>	≥ 60 dB
RF Output Level <sup>2</sup>	> 45 dBmV per channel at optical input of -10 dBm and 16% OMI
Operational Bandwidth	5-100 MHz
Flatness	
5-70 MHz	±0.5 dB
70-100 MHz	±1.0 dB
RF Attenuator Adjustment Range	30 dB
Impedance	75 Ω
Return Loss	> 16 dB
Connector Type	Female F
Isolation Between Receivers	
5 to 70 MHz	>65 dB
70 to 100 MHz	>40 dB

### User Interface

Front Panel	
Bi-state Status LED	Normal = Green, Alarm = Red
Module Selection Indicator	Yellow LED
Monitor Point	
Level	-20 dB +/- 1.0 dB relative to output
Return Loss	
5-65 MHz	-16 dB
65-100 MHz	-12 dB
Impedance	75Ω
Connector Type	Female F

### NETWatch™ Element Management System

HEM Monitor Port	RS-485, RS-232C connectors (in HLP 4200)
------------------	--

### Power Requirements

Input Voltage	+24 VDC; supplied by HLP 4200 bus
Consumption	15 W maximum

### Environmental

Operating Temperature Range	-0° to +50° C (+32° to 122° F)
Storage Temperature Range	-40° to +85° C (-40° to +185° F)
Relative Humidity Maximum	90% non-condensing

### Physical

Dimensions	3.0 cm W x 11.3 cm H x 24.3 cm D (1.20" W x 4.45" H x 11.53" D)
Weight	1.5 kg (3.3 lbs)
Mounting	HLP 4200 platform; via HMC 4008 module carrier

#### Notes:

- Two carriers at 45 dBmV/ch output level with -10 dBm optical input and 16% OMI.
- At maximum gain.