



Controller/Power Supply Module CPS 4248

Product Description

The CPS 4248 controller/power supply module is the intelligent engine of the HLP 4200 broadband platform. It provides microprocessor control of the high-efficiency switching power supply, controls the communication bus, and supplies +24 VDC power to the power bus.

The power supply board drives all modules in the HLP 4200 platform using a common DC power bus. The controller portion of the CPS 4248 module controls the communication bus of the HLP 4200 platform, and provides local and remote communications for system monitoring and control. The CPS 4248 provides an internal fault diagnostic menu that can be read on the HLP 4200WD display, or remotely by means of the NETWatch™ Element Management System. Microprocessor controlled regulation circuitry and over voltage/current protection ensure optimal performance and reliability, and a microprocessor-controlled fan maintains the unit's proper operating temperature.

The reliability of the CPS 4248 is further enhanced by powering the controller board directly from the platform bus, maintaining control in case of power supply board failure. A second CPS 4248 module may be installed in the platform and operated in a hot redundancy mode to enhance system reliability.

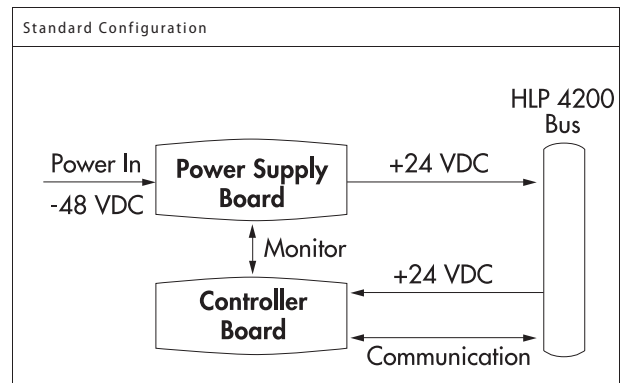

Advantages

The CPS 4248 module offers many advantages to enhance the power and flexibility of Harmonic's broadband communications equipment:

- Dual input capability provides redundant –48 VDC powering
- Highly efficient 264 Watt power supply reduces overall power consumption
- Over voltage protection enhances performance and reliability
- Microprocessor-controlled three speed fan automatically maintains optimal temperature, ensuring continuous, reliable operation
- On-line replaceable fan allows for uninterrupted service
- Automatic sensing of input –48 VDC voltage provides for ease of installation
- Detachable screw-type terminal block

User Interface

Front Panel	
Bi-state Status LED	Normal = Green, Alarm = Red
Module Selection Indicator	Yellow LED
Rear Panel	
	Detachable screw-type terminal block;
	62 pin D connector for controller cable to HLP 4200 platform

Output Power

Output Voltage	24.8 ± 1.0 VDC
Output Current	11 Amps maximum
Short circuit and over voltage protection	

Power Requirements

Input Voltage	-48 VDC, auto-sensing
Back-up Input Voltage	+24 VDC
Efficiency	80% minimum at full load
Consumption	30 Watts maximum (CPS 4248 only)
Fuse	Slow blow, 250 V, 6.3 Amps

Environmental

Operating Temperature Range	0° to +50° C +32° to +122° F
Storage Temperature Range	-40° to +70° C -40° to +158° F
Automatic 3-speed Fan Adjustment	Occurs at 40° & 50° C 104° & 122° F
Relative Humidity	Maximum 85% non-condensing

Physical

Dimensions	6.6 cm W x 11.2 cm H x 27.2 cm D 2.6" W x 4.4" H x 10.7" D
Weight	1.70 kg 3.75 lbs
Mounting	HLP 4200 platform; one module slot

