

HIGHLIGHTS

- Optimized for Cenelec international channel plans
- Reclaim fiber with DWDM technology
- Eight-wavelength solution for network segmentation and fiber-deep applications
- 1GHz RF bandwidth
- Up to 40km with optical amplification and 25 km with no amplification
- Integrated element management with SNMP compatibility
- Microprocessor control of all key parameters provides consistent and optimum product performance

Harmonic's family of 1550 nm SUPRALink™ transmitter modules is designed for advanced broadband networks. These DWDM transmitters can operate alone in local distribution or narrowcasting applications and in combination with Harmonic's node products for complete system solutions.

The DWDM SPL 7110C-Exx transmitter modules are very compact, with 10 transmitter modules fitting into a single three rack-unit high HLP4200 or HLP 4800 platform via the HMC 4001 module carrier adapter. They are intelligent and can be set up in a matter of minutes by means of the user-friendly interface. A user can configure a transmitter either via the platform display or the NETWatch™ Element Management System.



These transmitters allow service providers to deploy optical nodes deeper in the network while minimizing the cost of constructing new fiber routes. Each transmitter's ability to carry 1 GHz of analog and digital content simplifies network design and deployment. A user can scale the system in one-wavelength increments up to a maximum of eight wavelengths, providing a simple, seamless, "pay-as-you grow" expansion path. Its superior fiber reach enables service providers to design and maintain a transmission network in a single wavelength band, resulting in significant operational advantages.

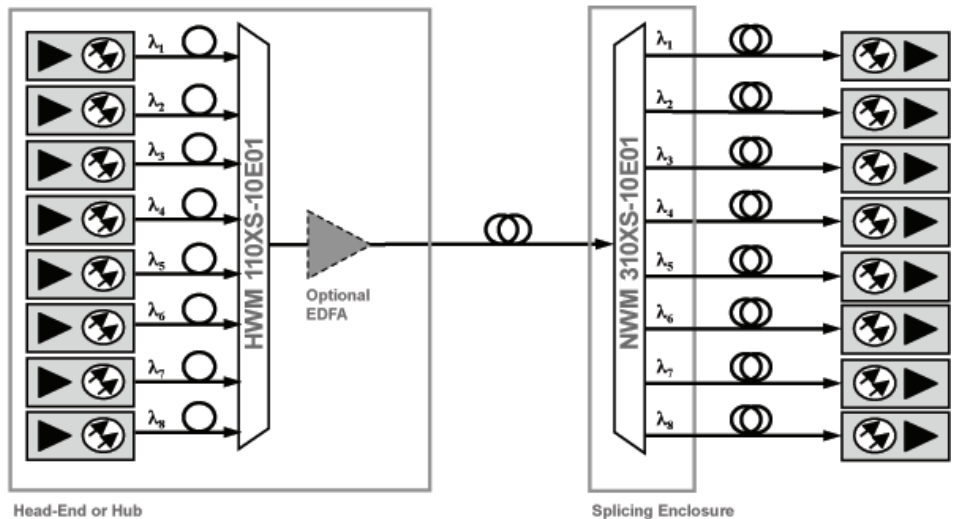

Typical Application

## MODELS AVAILABLE

SPL 7110C-Exx-zz

Exx = Channel number (01, 02, 03, 04, 05, 06, 07, or 08)

zz = Connector type (AS, AF, or AE)

## TYPICAL SYSTEM PERFORMANCE

Link Distance	25km with 4 wavelengths
Carrier-to-noise (CNR)	> 50.5 dB
Carrier-to-CSO	> 60 dB
Carrier-to-CTB	> 65 dB
Link Distance	25km with 8 wavelengths
Carrier-to-noise (CNR)	> 50.5 dB
Carrier-to-CSO	> 60 dB
Carrier-to-CTB	> 65 dB
Link Distance	40km with EDFA and 4 wavelengths
Carrier-to-noise (CNR)	> 49.0 dB
Carrier-to-CSO	> 58 dB
Carrier-to-CTB	> 65 dB
Link Distance	40km with EDFA and 8 wavelengths
Carrier-to-noise (CNR)	> 49.0 dB
Carrier-to-CSO	> 58 dB
Carrier-to-CTB	> 65 dB

See notes 1 through 6.

## OPTICAL OUTPUT

Model	Optical Power
SPL 7110S-EXX	9.5 ± 0.5 dBm <sup>7</sup>

## RF INPUT

Input Level Range per Unmodulated Analog Channel	16 dBmV to 20 dBmV
Operational Bandwidth	50 to 1003 MHz
Frequency Response	<1 dB peak-to-valley typ. <sup>8</sup>
RF Attenuator Adjustment Range	5 dB
Impedance	75 Ω
Return Loss	> 16 dB (50 - 870MHz) > 14 dB (870 - 1003 MHz)
Level Control	Manual (MGC) / Automatic (AGC) Auto set-up feature

## USER INTERFACE

Front Panel	
Bi-state Status LED	Normal = Green, Alarm = Red
Module Selection Indicator	Yellow LED
RF Attenuation Adjustment	
Monitor Point	
Laser RF Drive Monitor	
Return Loss	> 16 dB
Connector Type	Female F
Level	-20 ± 1 dB below input

## POWER REQUIREMENTS

Nominal	+24 VDC, supplied by platform bus
Consumption	22 Watts maximum

## ENVIRONMENTAL

Operating Temperature Range	0° to 50° C 32° to 122° F
Storage Temperature Range	-40° to 70° C -40° to 158° F
Relative Humidity	Maximum 85% non-condensing
Laser over temperature protection	

## PHYSICAL

Dimensions (WxHxD)	1.3" x 4.4" x 12.7" 3.3cm x 11.2cm x 32.2cm
Weight	2.1 lbs / 0.95 kg
Mounting	HLP 4200 or HLP4800 platform; via HMC module carrier
Optical connector type <sup>9</sup>	SC/APC
RF connector type	Standard F, RG-59 cable type (accepts 0.64-0.8 mm center conductor diameter)

### Notes:

1. Channel loading: 41 unmodulated Cenelec channels 119-855 MHz with 56 QAM256 channels (87-847MHz) at -6dBc relative to the analog carriers.
2. Pre-FEC BER maximum 1x10<sup>-6</sup>.
3. System performance specifications include fiber, wavelength multiplexer and de-multiplexer, optional EDFA, and NRM3111A receiver.
4. For operation over entire temperature range, subtract 0.5dB from CNR for 25km links and 1dB for 40km links.
5. For operation over the entire temperature range and worst case polarization state subtract 1 dB from C/CSO for 25km links and 3dB for 40km links. C/CSO is specified for in-band beats only.
6. Analog content on each wavelength must be identical with delay less than 100 meters or crosstalk impairment will result.
7. Optical power 9.5 ± 1dBm worst case due to measurement variation.
8. For operation over the entire temperature range add 0.5 dB to flatness.
9. SC/APC is the connector type recommended by Harmonic. Other connector types are available upon request.